

CENCON ATM SECURITY LOCK



INSTALLATION INSTRUCTIONS

TABLE OF CONTENTS

INTRODUCTION	1
DESIGN PARAMETERS FOR THE LOCK.....	2
PREPARE FOR NEW INSTALLATION OF THE LOCK	2
BASIC TOOLS AND MATERIALS NEEDED.....	3
LOCK PARTS FOR INSTALLATION	4
INSTALLATION KIT CONTENTS.....	5
TEMPLATE.....	6
INSTALL THE LOCK	7
INSTALLATION OF THE LOCK CASE	7
INSTALLATION OF THE FRONT COVER.....	8
INSTALLATION OF THE DIAL.....	9
INSTALLATION COMPLETION CHECKLIST	11
BASIC LOCK OPERATIONS.....	14
SHELVED MODE OPERATING INSTRUCTIONS.....	14
GEN2 LOCK MENU COMMAND LIST	15
CENCON LOCK LCD TERMINOLOGY	16
QUERY THE LOCK VIA KEYPAD	17
CHANGE SHELVED MODE COMBINATION	19

INTRODUCTION

Please read all instructions carefully before you install and use your Cencon ATM Security Lock. This will help you avoid unnecessary costs and concerns resulting from improper installation.

The installation instructions are the basis for Security Agency Approvals. The lock installation must be done in accordance to these instructions in order to maintain the labeled approval level.

Please note that there are three front cover options for the Cencon ATM Security Lock. See photographs below. These installation instructions apply to all versions.



KU Housing
(Keypad Up)



KD Housing
(Keypad Down)



KI Housing
(Keypad Inverted)

DESIGN PARAMETERS FOR THE LOCK

1. Bolt dimensions (nominal): .312 inches X 1.000 inches / 8 X 25.4 mm
2. Bolt movement (nominal) : .465 inches /11.8 mm
3. Maximum axial load movable by the bolt: 22 N (5# force)

Note: *The lock will not open if excessive force is applied to the end or side of the bolt.*

4. Maximum static load against bolt when thrown (all directions): 1kN (225#)
5. The lock can be fitted to safes or vault doors of any material.

Note: *As is the case with all mechanical and electronic locking devices, the container and bolt works must be designed to protect the lock.*

PREPARE FOR NEW INSTALLATION OF THE LOCK

1. Use the template to establish the exact locations (relative to the spindle hole) of the mounting holes for the lock.
2. The Lock Case mounting screws (English: 1/4-20, Metric: M6-1) require drilled and tapped holes to 3/8" depth if possible (minimum 1/4" depth required).
3. The Mounting Plate mounting screws (English: 8-32 or 10-32, Metric: M4 x.7) require drilled and tapped holes to 3/8" depth if possible (minimum 1/4" depth required).
4. The spindle hole diameter can be a minimum of .406" (10.32mm) to a maximum diameter of .438" (11.11mm). The .406" (10.32) diameter is recommended.
5. Deburr the spindle hole, ensuring that there are no sharp edges that could cut the cable.
6. When mounting the lock unit (i.e., integrating it in a bolt work), make sure that the lock bolt has clearance to freely move to its end positions and that the shifting force works only in the axial direction (direction of movement). Lateral forces should not be exerted on the lock.
7. If other parts of the bolt work are to be connected to the lock unit (e.g., for activating a blocking device), corresponding adapters can be fixed with the appropriate two screws (M4-.7 x 15mm, 10-32 x .563, or 10-32 x .500 screws, for the 005, 006, and 007 bolts respectively.) to the front of the lock bolt (tightening torque for 15mm screwing depth: 200Ncm maximum).

BASIC TOOLS AND MATERIALS NEEDED

1. Small Phillips head screwdriver (#1)
2. Medium Phillips head screwdriver (#2)
3. Large flat blade screwdriver
4. Standard hacksaw (32 teeth/inch)
5. Small flat file
6. All purpose scissors
7. ESD-protective wrist band (grounding strap)

RECOMMENDED, BUT NOT REQUIRED:

8. Torque screwdriver (30 inch-pounds/3.4 newton-meter capacity)
9. Loctite[®] 262 (Red) for use on Lock Case mounting screws
10. Tool for seating Dial washer (i.e., removable tip screwdriver)
11. Small vise to hold Spindle while cutting

TABLE OF RECOMMENDED TORQUES FOR CENCON LOCK SCREWS

APPLICATION	SCREW P/N	SCREW SIZE	TORQUE IN-LBS	TORQUE N-M
Lock Case cover	105030	6-32	9.0 to 11	1 to 1.25
Mounting Plate	205057 or 205013 or 205166	8-32 or M4 or 10-32	17 to 20	1.9 to 2.25
Front Cover	205056	6-32	9 to 11	1 to 1.25
Spindle	105036	6-40	14 to 16	1.6 to 1.8
Lock Case mounting	105046 or 205014	1/4-20 or M6	25 to 30	2.8 to 3.4

LOCK PARTS FOR INSTALLATION

1. Lock Case with Back Cover and cable
2. Front Cover (Keypad Up shown)
3. Mounting Plate
4. Dial
5. Dial Nameplate Decal
6. Cable AntiStatic Protector Bag
7. Spindle
8. Plastic Tube
9. Re-lock Reset Tool
(not shown in photo, will be taped to lock case back cover)

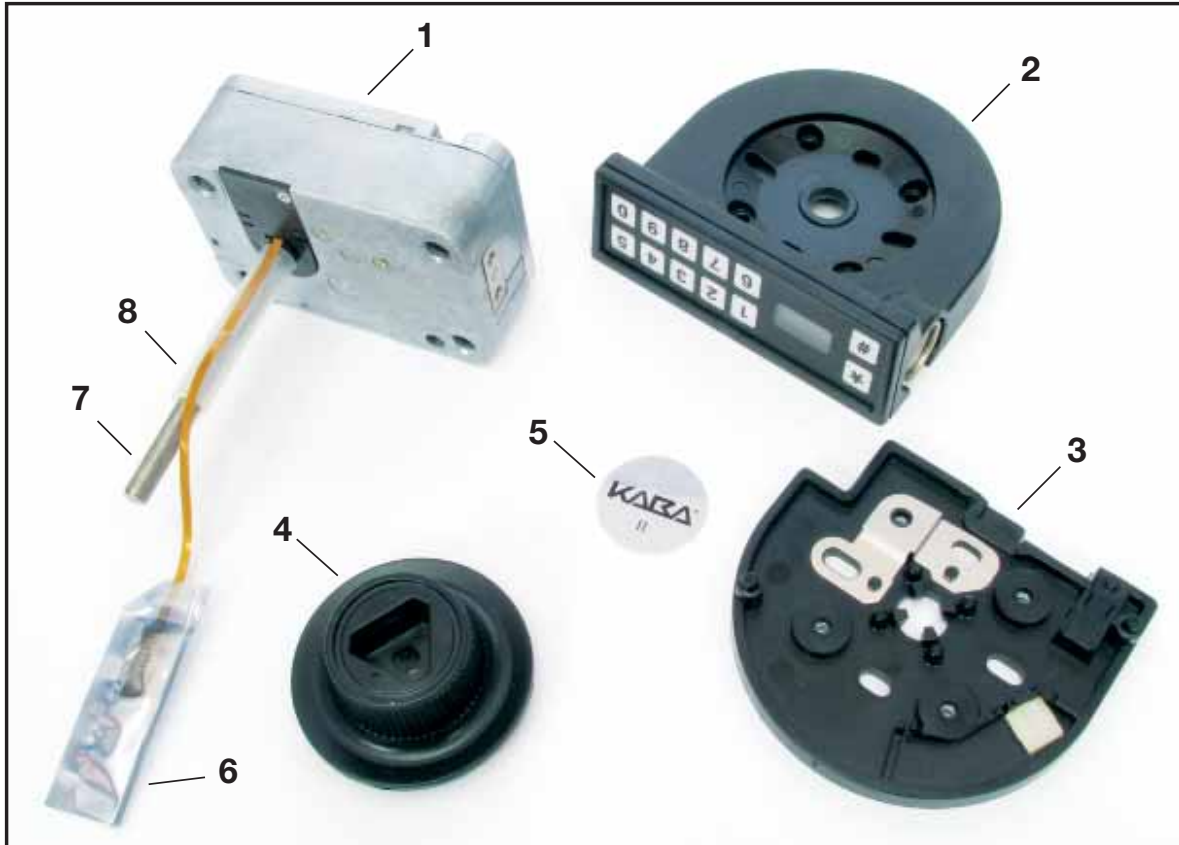

Figure 1 - Lock Parts for Installation

WARNING: Kaba Mas locks are protected from Electrostatic Discharge (ESD) damage once they are installed, but can be damaged during the installation process if proper precautions are not observed. Follow these precautions to avoid ESD damage when installing the lock:

- **DO NOT TOUCH** the contacts on the end of the lock cable, the blue zebra connector, or the cable under the zebra connector found in the keypad.
- Handle the front cover and the Lock Case back cover by the outer edge only.
- For the best protection, use an ESD wrist band grounded to the Lock Case or metal container during installation.

INSTALLATION KIT CONTENTS

1. Cable Shields (2)
2. Insulator Tape (in some configurations, lock shipped with cable taped to tube.)
3. Screw, Lock Case mounting, PH M6-1 x 10mm (4) blue-colored
4. Screw, Mounting Plate, PH M4-.7 x 10 mm (2)
5. Screw, Lock Case mounting, 1/4-20 x 3/8 inch (4) silver-colored
6. Screw, Lock Case mounting, 1/4-20 x 5/16 inch (4) brass-colored
7. Screw, Mounting Plate, PH 8-32 x 5/16 inch SEMS (2)
8. Tube Cut-Off Gauge
9. Screw, Front Cover, PH 6-32 x 3/8 inch SEMS (4)
10. Screw, Mounting Plate, PH 10-32 x 1/2 inch SEMS (2)
11. Lubricant (for Dial only)
12. Dial Clip
13. Dial Washer

Note: The install kit listed is part number 204004 (option 1 in lock cogfirator), which includes both metric thread and standard English thread screws. Items 5, 6, and 7 are not included in the metric install kit (p/n 204248).

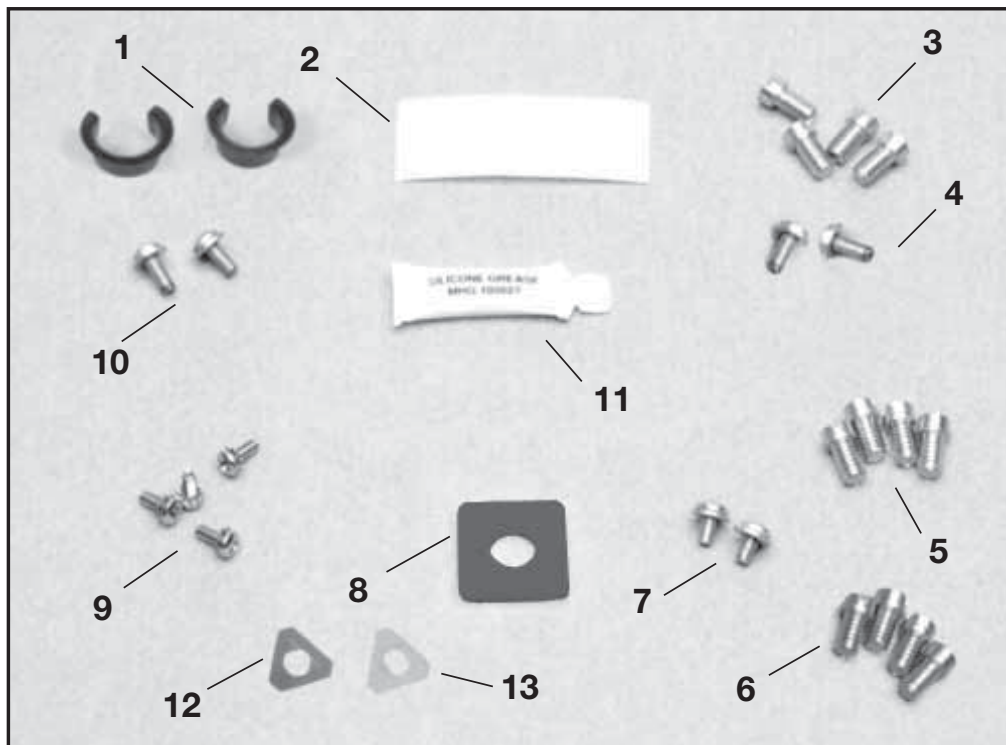
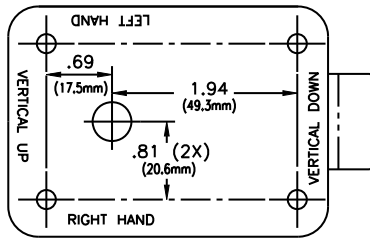

Figure 2 - Installation Kit Contents

TEMPLATE

A template is provided as an aid for locating, drilling, and tapping the Lock Case and Mounting Plate mounting screw holes relative to the Spindle hole. Since the lock is designed to fit most industry standard container lock mounting screw hole patterns, the need to use this template should be minimal.



LOCK CASE MOUNTING TEMPLATE
LARGE HOLE — .375 (9.53mm) MIN.
— .406 (10.32mm) RECOMMENDED
— .438 (11.11mm) MAX
SMALL HOLES - DRILL AND TAP:
ENGLISH: 1/4 - 20
METRIC: M6X1

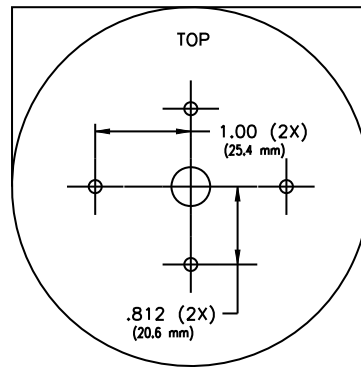

MOUNTING PLATE MOUNTING TEMPLATE
LARGE HOLE — .375 (9.53mm) MIN.
— .406 (10.32mm) RECOMMENDED
SMALL HOLES - DRILL AND TAP:
ENGLISH: #8-32
METRIC: M4X0.7

Note: The above template is NOT actual size. DO NOT USE for locating, drilling, and tapping the container for lock installation. A template of actual size is included with the lock for installation purposes.

INSTALL THE LOCK

INSTALLATION OF THE LOCK CASE

WARNING: *Do not extend the bolt prior to removing the Back Cover or while the Back Cover is removed. If this does occur, refer to page 10.*

1. Insert a Cable Shield into the spindle hole from the back side of the container door. (Figure 3)
2. Remove the two screws from the Lock Case cover, and carefully remove the Cover, pulling straight back. Detach the solenoid cable from the 90° 2-pin connector on the circuit card.
3. Remove the Drive Cam and Spindle from the Lock Case.
4. Slide the antistatic protector bag from the end of the cable.
5. The lock is often shipped with the tube in place on the lock case tube retainer and the cable taped to the tube in order to protect the cable.

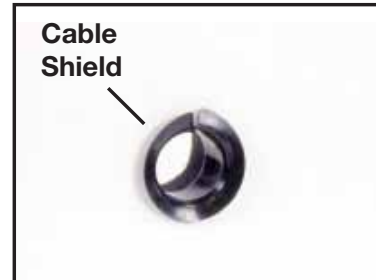

Figure 3 - Insert cable shield from back side

Note: *Be very careful not to put excessive strain on the cable when handling this assembly.*

If necessary, temporarily remove the tape to cut the tube. Carefully guide the end of the cable and the tube through the container wall so that they are easily accessible at the outside wall of the container.

6. Attach the Lock Case to the container wall using the appropriate Lock Case mounting screws (4.)

Note: *It is recommended that you use Loctite® 262 (Red) on the Lock Case mounting screws.*

7. The tube should extend at least 1/8 inch (3.2mm) outside the container wall.
8. Insert the second cable shield into the spindle hole from the front of the container with the cable feeding through the center of it. (See Figure 4.)

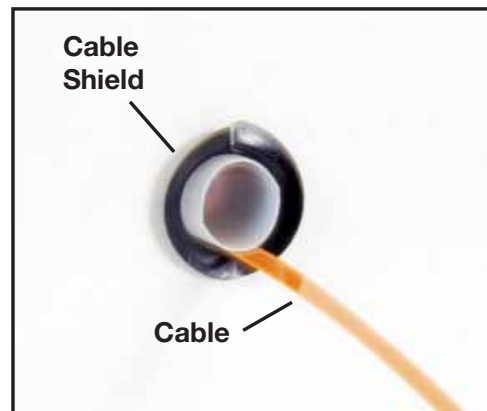

Figure 4 - Insert cable shield from front side

9. Check the amount of tube extending through the container wall using the Tube Cut-Off Gauge. When the Tube Cut-Off Gauge is placed next to the tube, the tube should be flush to 1/32 inch (0.8mm) below the surface of the gauge.

10. Carefully guide the end of the cable through the center of the Tube Cut-Off Gauge and then slide the Tube Cut-off Gauge over the Tube. Position the Gauge flush against the Container wall.
11. If the tube extends beyond the gauge, using the gauge as a guide, mark the tube at the surface of the gauge for cutting. Use a pair of scissors to cut the tube, just inside the mark. Temporarily remove tube from Lock Case if necessary.

WARNING: *Be very careful not to cut the cable!*

INSTALLATION OF THE FRONT COVER

1. Guide the cable through the center hole of the Mounting Plate and position the Mounting Plate (as shown in Figure 5) over the exposed tube and against the outside wall of the container.

Note: If you are mounting the KD housing model, rotate the position of the Mounting Plate by 180° so that the rounded portion of the mounting plate is at the top.

2. Attach the Mounting Plate using the appropriate screws (and washers, if SEMS type screw/washer assemblies are not provided.)
3. Center the Mounting Plate and tube to the container spindle hole as best you can, while keeping the top of the Mounting Plate as near horizontal as possible.
4. Tighten the screws. You will have access to these screws through the Front Cover to make necessary adjustments, if needed.
5. Slide the end of the cable, with the gold contact pads facing outward, into the slotted cable support area in the upper right corner of the Mounting Plate. The hole in the cable must be positioned over the locating button in this area and the cable must lie flat against the support surface.
6. The cable must now be turned 90° and laid in the slots in the **cable containment area** to insure that it is safely controlled and out of the way for attaching the Front Cover to the Mounting Plate. Route the cable through the plastic cable retainer. (See Figure 5.) If any excess cable is sticking up, wrap it up and tape it down in an area of the Mounting Plate that will not get pinched by a screw.



Figure 5 - Route Cable through Retainer (KU housing shown)

7. Check the inside of the Front Cover and ensure that the blue zebra connector and its black plastic housing is properly seated. **WARNING:** Do not touch the blue zebra connector. It must remain clean.
8. Place the Front Cover onto the Mounting Plate and insert and tighten its attaching screws (4.) Please follow the recommended tightening order as follows:

For Keypad Up (KU) housing:

- 1) UPPER LEFT; 2) LOWER RIGHT; 3) LOWER LEFT; 4) UPPER RIGHT.

For Keypad Down (KD) housing:

- 1) LOWER RIGHT; 2) UPPER LEFT; 3) UPPER RIGHT; 4) LOWER LEFT

INSTALLATION OF THE DIAL

1. Install the Drive Cam/Spindle into the Lock Case until the Drive Cam is properly seated and the spindle extends through the Front Cover.

Note: Lift the lever and turn the cam to make sure the cam is seated properly. When properly seated, there should not be a gap between the rear of the cam and the lever. The cam must be seated so that the latch of the lever is positioned in the “low dwell” of the cam. (See Figure 6.)

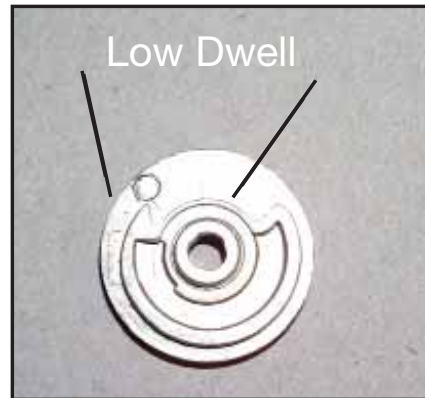

Figure 6 - Low Dwell of the Cam

2. While holding the Drive Cam in its proper position in the Lock Case, inside the container, push the Dial onto the Spindle.
3. Mark the Spindle just below flush with the decal surface of the Dial. (See Figure 7.)
4. Remove the Spindle from the Lock Case to prevent damage to the cable while cutting.



Figure 7 - Mark Spindle Below Flush

5. Use a hacksaw to cut the Spindle on the mark. You may want to use a small vise to secure the Spindle when cutting.
6. Use a file to deburr and bevel the Spindle edges after cutting.
7. Install the Drive Cam/Spindle once again into the Lock Case until the Drive Cam is properly seated and the Spindle extends through the Front Cover.
8. Attach the solenoid cable to the 90° 2-pin connector on the circuit card.

Caution: *If the bolt has become extended during installation, DO NOT try to move the solenoid plunger manually in order to retract the bolt. This action will damage the lock. Instead, the bolt should be left in the extended position and the Re-lock Trigger must be reset by completing Steps 8a-8g. If the bolt is not extended, continue to Step 9.*

To reset the Re-lock Trigger if the bolt has become extended:

- 8a. Making sure the solenoid cable is not pinched, carefully mount the Back Cover onto the Lock Case.
- 8b. With the Back Cover placed on the Lock Case, start the Cover screws but do not tighten.
- 8c. Insert the Re-lock Reset Tool (located under the Caution label on the lock) into the Re-lock Trigger Reset hole and wedge the Tool firmly into the hole.
- 8d. Pull out gently on the Re-lock Reset Tool. This action will lift the Re-locking Pin out of the bolt.
- 8e. While holding the pin out of the bolt with the Reset Tool, push slightly on the Back Cover until it seats fully flush against the Lock Case.
- 8f. While holding the Back Cover tightly in place, tighten the cover screws.
- 8g. Remove the Re-lock Reset Tool, and replace it under the Caution label.

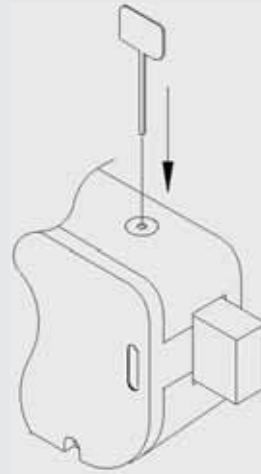

9. Route solenoid cable between Lock Case wall and the “U” part of solenoid cover to avoid pinching by Back Cover (see Figure 8).

10. Place the Back Cover back on the Lock Case.



Figure 8 - Route cable properly.

WARNING: *Ensure the Back Cover is fully seated before proceeding in order to provide proper spacing for Dial installation.*

11. Insert and tighten the two Back Cover screws.

12. Apply lubricant from install kit around the bearing surface of the hub of the Dial. (See Figure 9.)



Figure 9 - Apply Lubricant to Dial.

13. Push the Dial onto the Spindle until it seats against the Front Cover.

14. Complete the following Installation Completion Checklist and test the operation of the lock before completing the installation and closing the container door:

Installation Completion Checklist

A. Ensure that that Dial turns freely without scraping or binding.

If an undesirable amount of rotational drag exists when turning the Dial, the Mounting Plate may not be properly aligned with the Lock Case. Remove the Dial. Check the alignment of the Mounting Plate in relation to the spindle hole and Lock Case as a cause of the Dial binding. Adjust the Mounting Plate screws if necessary. Replace the Dial and ensure that the Dial turns smoothly and easily.

B. Ensure the lock properly powers up to display “**EC.**”

Turn the Dial left (CCW) until the letters “EC” (Enter Combination) appear on the LCD.

If there is nothing on the LCD after 60 seconds of dialing, there is likely a bad connection. Remove the Dial and the Front Cover and check that the gold connector leads on the cable are in the proper position, facing away from the door. If the cable is cut or severely crimped, the cable will have to be replaced by removing the Lock Case. Also ensure that the blue zebra connector is in place in the Front Cover and has been wiped of debris by a clean cloth. Replace the Front Cover and the Dial and attempt power-up again.

C. Test the operation of the lock according to the **Factory Mode Operating Instructions** on page 14.

Continue with the following **Installation Completion Checklist**. Ensure that after “**OPr**” displays, the bolt will retract.

C.1 If after “**OPr**” displays, and the Dial is turned to the right more than 5 revolutions without retracting the bolt, try again with slower or faster speeds after the “**OPr**”. If bolt still remains extended, remove the Back Cover and check the following:

- Ensure that the cam is properly seated flat towards the container-side of the lock case so that the drop lever engages with the cam.
- Ensure the solenoid cable is properly connected to the 2-pins and is not cut or severely crimped. Do not attempt to remove or manipulate the solenoid.

C.2 If after “**OPr**” displays, and the Dial is turned to the right and stops turning without retracting the bolt, the re-locker has been triggered.

Refer to Step 8 on page 10 to reset the re-locker. Then retest the Factory Combination to ensure the lock bolt retracts.

15. Place the Dial Washer onto the Spindle and slide the washer down into the triangular shaped recess of the Dial until the washer is fully seated in the recess. (See Figure 9.)

16. Use a tool to push the Dial Washer into the recess until it is firmly seated.

17. Position the Dial Clip over the Spindle in the center of the front of the Dial. (See Figure 10.) The raised tabs on the clip should be facing out away from the lock (i.e., the concave side of the clip should be facing into the recess.)

18. Push the clip down into the recess until it is firmly seated against the washer.

Note: *If the clip is not firmly seated, you will have excessive end play in the Dial.*



Figure 9 - Slide Washer into Recess



Figure 10 - Seat Clip over Washer

19. Rotate the Dial CCW to extend the bolt (if not already extended.)

20. Test the operation of the lock again according to the **Factory Mode Operating Instructions** on page 14 until you are comfortable with the operation of the lock.

If an undesirable amount of rotational drag still exists when turning the Dial, the Dial Clip may be seated too tightly over the Spindle and Dial Washer, or no lubricant was applied. Complete the following steps to remove the Dial and redo that portion of the installation:

- a. Remove the Back Cover.
- b. Remove the Spindle screw at the Cam-end of the Spindle.
- c. Remove the Spindle/Dial assembly from the front of the container.
- d. Slide the Dial and washer easily off the screw-end of the Spindle. The clip will also slide off that direction, but will require more effort.
- e. Reinstall the spindle screw into the threaded end of the Spindle and tighten securely. (Loctite recommended.)
- f. Return to Step 7 of the Dial Installation instructions, and redo the remainder of the installation. You do not have to complete Step 11 (apply lubricant) since that was done previously.

21. If the lock operates properly, ensure that all screws have been securely tightened, using Locktite[®] 262 (Red) on the recommended screws mentioned previously and on the two Back Cover screws.
22. Apply the decal to the Dial. (See Figure 11.)

The installation is now complete.



Figure 11 - Apply Dial Decal

BASIC LOCK OPERATIONS

For the complete Cencon lock and software operating instructions in FLM, Route, and Bank modes, please see the Cencon Reference Manual on the documentation section at www.Kaba-Mas.com.

Shelved Mode Operating Instructions:

Each lock is shipped from the factory in Shelved Mode (a.k.a. Factory Mode), operating on a standard combination (50-25-50). The “One-Time-Combination” (OTC) + SmartKey opening process does not function when the lock is in this Shelved Mode condition. The opening procedure for a Shelved Mode lock is the following: *Until the installation and operation of the lock have been verified with several openings, these steps should first be performed with the safe door locked open.*

1. Turn the Dial left (CCW) until the letters “**EC**” (**E**nter **C**ombination) appear on the LCD. (“**-dL**” will appear first signaling to dial left.)
2. Enter the factory combination of **50-25-50** by sequentially pressing those six buttons. The LCD will display these numbers as they are entered.
3. When the combination has been correctly entered, the LCD will read “**OPr**,” meaning “**OP**en right.”
4. Turn the Dial right (CW) until it stops. The lock’s bolt is now retracted and the lock is open.
5. Turn the Dial left (CCW) a full revolution to extend and secure the lock’s bolt.
6. To test that the bolt is securely closed, turn the dial back to the right and ensure the bolt remains extended.

Try this several times until you are comfortable with the operation of the lock.

Note: *If you realize that you have accidentally entered an incorrect number as part of the combination, there is no “backspace” key. You can hold down the * key to clear. Then, you would repower the lock and start again.*

Wrong Try Penalty: *If the shelved mode combination is entered incorrectly a lightning bolt will appear and will continue to flash until the LCD powers down after 40 seconds or until the * key is held down. 5 simultaneous wrong combination attempts will result in a “LCO” condition (LockOut). If this occurs, let the lock power down for at least 5 minutes, and then enter the correct combination to open the lock, clearing the LCO condition.*

GEN2 LOCK MENU COMMAND LIST

# #	Display Audit Count (opening count) ¹	(see Ref. Manual)
# 0	Perform SA Key Operations (audit download, resync, clock set, bank user table download, etc.).....	(see Ref. Manual)
# 1	Display Lock Level	p. 17
# 2	Display Lock's Serial Number	p. 17
# 3	Display Lock's Total Audit Count	p. 18
# 4	Display Last Close Seal ¹	(see Ref. Manual)
# 8	Change shelved-mode or bank user's combination	p.19
# 70	Display Active Modes and Activator Identification	(see Ref. Manual)
# 71	Display Internal UTC/GMT Date/Time	p. 18
# 72	Display Local Date/Time ¹	(see Ref. Manual)
# 73	Display Key Type and Key Serial Number ¹	(see Ref. Manual)
# 74	Display Door Contact Switch Status	p. 18
# 76	Display Activated Mode's Software Level ¹	(see Ref. Manual)
# 77	Display Personal Identifier Clock ¹	(see Ref. Manual)
# 78	Display Last Opening, Local Date/Time ¹	(see Ref. Manual)
# 79	Display Activation Event, Local Date/Time ¹	(see Ref. Manual)
*	Cancel an Operation, Combination or Clear a Repeating Display Prompt	(see Note below)

Note: *Some displayed data will repeat until the lock powers down (after 40 seconds) or the * key is held down.*

¹ Lock requires mode user key to be presented.

All the prompts that request that a user key (blue FLM, yellow Route, or green Bank) will do so by displaying the "IPI" after the command is entered. The difference to note is that #73 and #77 will be reading and displaying information unique to a particular key, whereas ##, #4, #72, #76, #78, and #79 are reading which particular mode this key is associated with (FLM, Route, or Bank) and then displaying information for that entire mode.

Previous to a lock being activated in any mode, the prompts ##, #4, and #70, 72, 76, 78 and 79 will display the ¹ error. #72 only applies to Gen2 locks activated with a USB Key Box.

After a particular mode is shelved, the ## and #4 prompts will still display "I P I" to give information about a mode the last time it was active, though the remaining #7x prompts mentioned will start showing the ¹ error again.

CENCON LOCK LCD TERMINOLOGY

The first step in learning the operation of the Cencon Lock is understanding what is shown on the display.

Note: *The Cencon LCD uses a 7-segment font, displaying up to 3 characters at a time. Some displays will be a mixture of numbers and both capital and lower case letters.*

Lock Displays/Prompts Used on Both Gen1 and Gen2

1. **-dL** = **Dial Left** to get to EC prompt after extending bolt
2. **EC** = **Enter Combination**
3. **OPr** = **OPen Right** to retract the lock bolt
4. **EcC** = **(Change Key Inserted) Enter shelved mode Combination**
5. **EcF** = **Enter Current combination (Shelved mode/Factory)**
6. **EnF** = **Enter New combination (Shelved mode/Factory mode)**
7. **CnF** = **Confirm New combination (Shelved mode/Factory mode)**
8. **⚡** = **Lightning Bolt (Error); usually wrong combination**
9. **LCO** = **LockOut** condition due to 5 lightning bolts
10. **IP1** = **Insert Personal Identifier (key) 1**
11. **c00** = **Close Seal** number (where 0 is a number)
12. **EDP** = **End OPeration (or End Of Process)**
13. **?-** = **"?"** displayed when the command key (#) is pressed
14. **SC-** = **(##) - Seal Count**** for an active mode by user key
15. **SS-** = **(##) - Seal count**** for a **Shelved** mode by user key
16. **LL-** = **(#1) - Lock firmware code Level**
17. **HL-** = **(#1) - Hardware Level** of lock back cover
18. **Sn-** = **(#2) - Serial Number** of lock back cover
19. **AC-** = **(#3) - Total (All modes) opening Count**

**Seal count, Opening Count, and Audit Count are terms used interchangeably throughout the documentation.

Lock Displays/Prompts Found Only on Gen2:

21. **G 2** = Indicates **Gen2** lock during power-up
22. **rLO** = **Remote Lock Out** signal; keypad entry is prevented
23. **UtC** = **(#71) - UTC/GMT** date and time of lock
24. **Yr-** = **(#71) - Date**, starting with **Year**, then Month, then Day
25. **Hr-** = **(#71) - Time**, starting with **Hour**, then Minute, then Second
26. **CI** = **(#73) - Cencon iButton (key) Model Number**
27. **CS** = **(#73) - Cencon iButton (key) Serial Number**
28. **OPd** = **(#74) - OPened Door**
29. **CLd** = **(#74) - CLosed Door**
30. **nCC** = **(#74) - No door Contact Connection**
31. **PI C** = **(#77) - UTC/GMT** date and time on **Personal Identifier Key's Clock**

For a full listing of Lock LCD Terminology, including displays only shown while the lock is activated, see the Cencon 4 Software Reference Manual, Appendix C.

QUERY THE LOCK VIA KEYPAD

The Gen2 lock allows the user to gather information in the field simply by pressing keypad commands, sometimes presenting their user key, and then reading the LCD.

DISPLAY LOCK LEVEL (#1)

It is sometimes necessary to determine the code level of the Cencon Lock with which you are working. This can be done through the keypad with the level displayed on the LCD. Use the following procedure:

1. Power the lock by turning the dial counterclockwise until **EC** is displayed.
2. Enter the **#1** keypad command.
3. All Gen2 locks will display “**LL-**”, “**G 2**”, followed by 4 sets of 3 numbers, followed by “**HL-**” with 2 number pairs. If the LCD instead shows the letters “**LL-**” followed by a string of number pairs then “**HL-**” followed by 2 number pairs, then this lock is a Gen1 lock.

Note: To determine the exact Lock Level of a Gen1 lock, please refer to the Cencon Reference Manual.

DISPLAY SERIAL NUMBER (#2)

The Gen2 lock’s Serial Number is a 9-digit number. To display the Lock Serial Number, press “**#**” and then “**2**” when “**EC**” is displayed.

Until a time when the first 3 digits of the 9-digit serial number are non-zero, the lock will only display 6 digits. The Gen2 Cencon lock will display a series of two or three 3-digit numbers, depending on what the value of the first three numbers of the serial number are. When taken together, this series of numbers is the serial number of the lock.

Example 1: Gen 2 Serial Number (9 digits with first 3 digits “000”)

Serial number of the lock is “000023456”

The lock will display “**Sn-**” followed by a series of two 3-digit numbers: “**023**” “**456**”

Example 2: Gen 2 Serial Number (9 digits with first 3 digits non-zero)

Serial number of the lock is “001348729”

The lock will display “**Sn-**” followed by a series of three 3-digit numbers: “**001**” “**348**” “**729**”

DISPLAY TOTAL AUDIT COUNT (#3)

The lock always keeps track of how many times it has been opened (Total Audit Count) no matter in which mode the opening occurred, including Shelved Mode, FLM, Route, and Bank. To learn the Total Audit Count, press the pound symbol, “#,” followed by the “3” whenever “EC” is displayed on the LCD. The display will flash two sets of numbers alternately on the screen. When taken as one four-digit number, this represents the Total Audit Count. For instance, if the LCD flashes “AC-” then “00” followed by “07,” the lock has a Total Audit Count of “0007,” meaning the lock has been opened seven times in all modes combined. This display can be cancelled by pressing the asterisk (*) button. The Total Audit Count does not reset when the lock is shelved. Once the counter exceeds 9999 openings, the Gen2 lock begins displaying more digits.

DISPLAY INTERNAL GMT (UTC) DATE/TIME (#71)

The UTC/GMT date and time are initialized in a Gen2 lock at the time of manufacture at Kaba Mas. When #71 is pressed, the current lock date & time are displayed. This display can be canceled by pressing the asterisk (*) key, or it will automatically be canceled when the lock powers down.

For each of the commands that displays either current or historic Date and Time (#71, #72, #78, and #79), the format is the same: Starting from the largest time increment (4-digit Year) and moving down to the smallest (2-digit second). For readability, the date and the time are broken apart by the “Hr-” (hour) prompt in the middle.

(For example, “**UtC**”, “**Yr-**”, “ 20”, “ 09”, “ 12”, “ 25”, “**Hr-**”, “ 22”, “ 30”, “ 59”)

DISPLAY DOOR CONTACT SWITCH STATUS (#74)

The Gen2 lock has a 4-pin signal input cable to optionally use Door Contact switches and for a Remote Disable function. After installing the door contact switches, the customer will want to determine the status of these sensor, often while the lock is still in factory mode, and later when the lock is activated.

(For example, “**OPd**” for “OPened door”, “**CLd**” for “closed door”, or “**nCC**” for “no door contact connection” accordingly.)

Note: Check for Remote Disable Signal by entering 50-25-50 and looking for “**rLO**” on display before closing door.

CHANGE SHELVED MODE COMBINATION (#8)

For all Gen2 locks and those Gen1 locks with a code level of 71 or greater, you may change the Shelved Mode combination. You may change the default Factory Combination of 50-25-50 to a new combination to be used while the lock is still in Shelved Mode. Once you have changed the combination for the first time, you may want to change the combination again to a different Shelved Mode combination. You can even change it back to the Factory combination of 50-25-50.

Required Items: Change Key, Current Shelved Mode Combination

Note: *You can only change the Shelved Mode combination while operating in Shelved Mode. Once a lock is “activated” in any mode, the Shelved Mode combination returns to the Factory Default of 50-25-50.*

Warning: *Continuing to operate the lock in Shelved Mode, even after changing the combination from 50-25-50, is similar to the minimal security that a mechanical lock would provide. If the new 6-digit Shelved Mode combination is lost or forgotten, with the safe door closed, the door must be drilled. Therefore, it is recommended to take full advantage of the additional security audits, and access control of the Cencon lock by activating it with the Cencon software and using the SmartKeys for openings.*

To change the Shelved Mode combination:

1. **Power Lock → EC**
Turn the Dial to the left (CCW) until “**EC**” (**Enter Combination**) is displayed.
2. **EC → Enter Shelved Mode Combination → OPr**
Enter the current Shelved Mode combination (either 50-25-50 or a changed Shelved Mode combination) by sequentially pressing those digits on the lock keypad. The numbers will be displayed on the LCD as they are entered.
3. **OPr → Retract Bolt**
Turn the Dial to the right (CW) to retract the bolt
4. **Open Door**
5. **Insert Change Key**
Insert the change key into the change key socket on the back of the lock.
6. **Extend Bolt**
Do not close the door. Turn the Dial to the left (CCW) to extend the bolt.
7. **Power Lock → ⌫ EC**
Turn the dial to the left (CCW) until ⌫ **EC** (the Change Key symbol along with **Enter Combination**) is displayed.
8. **⌫ EC → Press #8 → EcF**
Press the “#” button followed by the “8” button. **EcF** (**Enter current Factory combination**) will be displayed.
9. **EcF → Enter Current Shelved Mode Combination → EnF**
Enter the current shelved mode combination, “**EnF**” (**Enter new Factory combination**) will be displayed.

10.EnF → Enter New Factory Combination → Cnf

Select and enter the new combination. “**CnF**” (**C**onfirm **n**ew **F**actory combination) will be displayed.

Note: *The new Shelved Mode combination should be recorded and stored in a secure area.*

11.CnF → Confirm new Factory combination → POC

Enter new combination again to confirm. **POC** (**P**ull **O**ut **C**hange key) will be displayed.

12.POC → Remove Change Key → EOP

Remove the change key. **EOP** (**E**nd **O**peration) is displayed.

13.EOP → Power Lock → EC

Turn the dial to the left (CCW) until **EC** (**E**nter **C**ombination) is displayed.

14.EC → Enter New Shelved Mode Combination → OPr

Enter the new shelved mode combination by pressing those digits on the lock’s keypad. The numbers will be displayed on the LCD as they are entered.

15.OPr → Retract Bolt

Turn the Dial to the right (CW) to retract the bolt.

16.Close Door

17.Extend Bolt

Turn the Dial to the left (CCW) to extend the bolt.

Document Number 2003.048
Rev. H - 12/09

Notice: The information in this manual is subject to change without notice and does not represent a commitment on the part of Kaba Mas. Kaba Mas shall not be liable for technical or editorial errors or omissions contained herein; nor for incidental or consequential damages resulting from the furnishing, performance or use of this material.

© 2001-2009 Kaba Mas

All rights reserved



Kaba Mas LLC
749 W. Short Street, Lexington, KY 40508 USA
Phone: (859) 253-4744 FAX: (859) 255-2655
Technical Support: (800) 950-4744
www.kaba-mas.com